

概述

MAX3737为+3.3V激光驱动器，专为数据速率从155Mbps至2.7Gbps的多速率收发模块而设计。激光器直流耦合到MAX3737，减少了外部元件数量，易于多速率运行。

激光器消光比控制(ERC)包括自动功率控制(APC)、调制补偿和片内温度补偿等功能。APC环路保持平均光功率恒定；调制补偿根据偏置电流调节调制电流。这些控制环路具有温度补偿，在整个温度范围和有效使用期限内保持恒定的消光比。

MAX3737接受差分数据输入信号。5mA至60mA(交流耦合时高达85mA)的宽调制电流范围和高达100mA的偏置电流范围，使MAX3737尤其适合于驱动光模块中的FP/DFB激光器。外部电阻设置所需的激光器电流值。MAX3737提供发送禁止控制(TX_DISABLE)、单点故障容限、偏置电流监视、调制电流监视及光电流监视。该器件还提供一个锁定的失效输出(TX_FAULT)，用于指示故障，例如APC回路无法保持期望的平均光功率时。MAX3737符合SFF-8472发送器诊断及SFP MSA定时要求。

MAX3737提供32引脚、5mm x 5mm薄型QFN封装或QFN封装，工作在-40°C至+85°C的扩展级温度范围内。

应用

多速率OC-3至OC-48 FEC收发器

千兆位以太网SFF/SFP和GBIC收发器

1Gbps/2Gbps光纤通道SFF/SFP和GBIC收发器

功能图及典型应用电路参见数据资料的末尾部分。

特性

- ◆ +3.3V单电源供电
- ◆ 47mA电源电流
- ◆ 85mA调制电流
- ◆ 100mA偏置电流
- ◆ 自动功率控制(APC)
- ◆ 调制补偿
- ◆ 片内温度补偿
- ◆ 用于交流耦合的自偏置输入
- ◆ 以地为参考的电流监测
- ◆ 激光器安全电路、关断和报警输出

订购信息

PART	TEMP RANGE	PIN-PACKAGE
MAX3737ETJ	-40°C to +85°C	32 Thin QFN
MAX3737ETJ+	-40°C to +85°C	32 Thin QFN
MAX3737EGJ	-40°C to +85°C	32 QFN

+Denotes lead-free packaging.

引脚配置

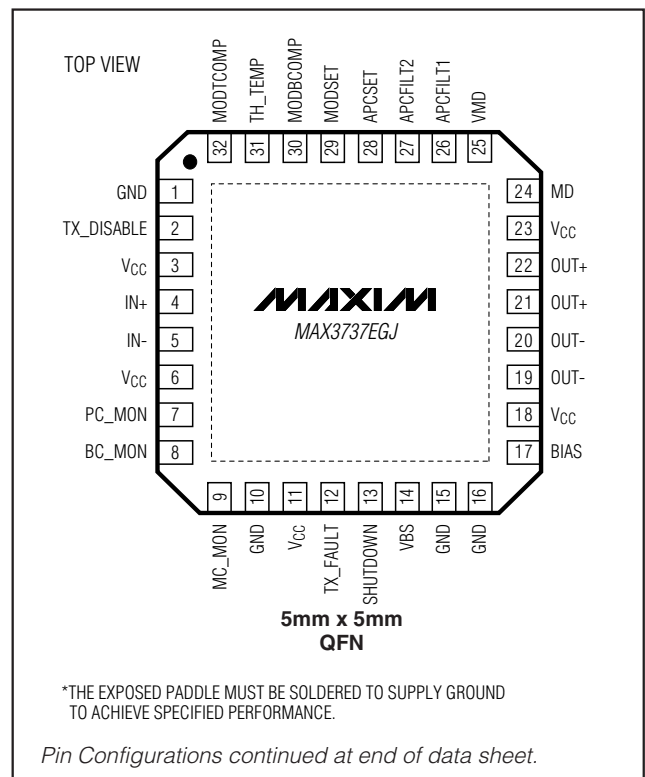

多速率激光驱动器， 带有消光比控制

ABSOLUTE MAXIMUM RATINGS

Supply Voltage V_{CC}	-0.5V to +6.0V	OUT+, OUT-, BIAS Current.....	-20mA to +150mA
IN+, IN-, TX_DISABLE, TX_FAULT, SHUTDOWN, MC_MON, BC_MON, PC_MON, VBS, VMD, APCFILT1, APCFILT2, MD, TH_TEMP, MODTCOMP, MODBCOMP, MODSET, and APCSET Voltage.....	-0.5V to $V_{CC} + 0.5V$	Continuous Power Dissipation ($T_A = +85^\circ\text{C}$) 32-Pin QFN (derate 21.2mW/ $^\circ\text{C}$ above +85 $^\circ\text{C}$).....	1.3W
		Operating Junction Temperature Range.....	-55 $^\circ\text{C}$ to +150 $^\circ\text{C}$
		Storage Temperature Range.....	-55 $^\circ\text{C}$ to +150 $^\circ\text{C}$

Stresses beyond those listed under "Absolute Maximum Ratings" may cause permanent damage to the device. These are stress ratings only, and functional operation of the device at these or any other conditions beyond those indicated in the operational sections of the specifications is not implied. Exposure to absolute maximum rating conditions for extended periods may affect device reliability.

ELECTRICAL CHARACTERISTICS

($V_{CC} = +2.97V$ to $+3.63V$, $T_A = -40^\circ\text{C}$ to $+85^\circ\text{C}$. Typical values are at $V_{CC} = +3.3V$, $I_{BIAS} = 60\text{mA}$, $I_{MOD} = 60\text{mA}$, $T_A = +25^\circ\text{C}$, unless otherwise noted.) (Notes 1, 2)

PARAMETER	SYMBOL	CONDITIONS		MIN	TYP	MAX	UNITS
POWER SUPPLY							
Supply Current	I_{CC}	(Note 3)			47	60	mA
Power-Supply Noise Rejection	PSNR	$f \leq 1\text{MHz}$, 100mV _{P-P} (Notes 4, 6)			33		dB
I/O SPECIFICATIONS							
Differential Input Swing	V_{ID}	DC-coupled, Figure 1		0.2		2.4	V _{P-P}
Common-Mode Input	V_{CM}			1.7		$V_{CC} - V_{ID}/4$	V
LASER BIAS							
Bias-Current Setting Range				1		100	mA
Bias Off Current		TX_DISABLE = high				0.1	mA
Bias-Current Monitor Ratio		I_{BIAS}/I_{BC_MON}		68	82	95	mA/mA
LASER MODULATION							
Modulation-Current Setting Range	I_{MOD}	(Note 5)		5		85	mA
Output Edge Speed		20% to 80% (Notes 6, 7)	$5\text{mA} \leq I_{MOD} \leq 10\text{mA}$		71	80	ps
			$10\text{mA} < I_{MOD} \leq 85\text{mA}$		52	80	
Output Overshoot/Undershoot		(Note 7)			±6		%
Random Jitter		(Notes 6, 7)			0.65	1.3	ps
Deterministic Jitter (Notes 6, 8)		2.7Gbps	$5\text{mA} \leq I_{MOD} \leq 10\text{mA}$		25.6	40	psp-P
			$10\text{mA} < I_{MOD} \leq 85\text{mA}$		16	40	
		1.25Gbps	$5\text{mA} \leq I_{MOD} \leq 10\text{mA}$		32	41	
			$10\text{mA} < I_{MOD} \leq 85\text{mA}$		15	41	
		622Mbps	$5\text{mA} \leq I_{MOD} \leq 10\text{mA}$		39	46	
			$10\text{mA} < I_{MOD} \leq 85\text{mA}$		21	46	
155Mbps	$5\text{mA} \leq I_{MOD} \leq 10\text{mA}$		65	100			
	$10\text{mA} < I_{MOD} \leq 85\text{mA}$		46	70			
Modulation-Current Temperature Stability		(Note 6)			±150	±480	ppm/ $^\circ\text{C}$

多速率激光驱动器， 带有消光比控制

MAX3737

ELECTRICAL CHARACTERISTICS (continued)

($V_{CC} = +2.97V$ to $+3.63V$, $T_A = -40^\circ C$ to $+85^\circ C$. Typical values are at $V_{CC} = +3.3V$, $I_{BIAS} = 60mA$, $I_{MOD} = 60mA$, $T_A = +25^\circ C$, unless otherwise noted.) (Notes 1, 2)

PARAMETER	SYMBOL	CONDITIONS		MIN	TYP	MAX	UNITS
Modulation-Current Setting Error		15 Ω load, $T_A = +25^\circ C$	$5mA \leq I_{MOD} \leq 10mA$			± 20	%
			$10mA < I_{MOD} \leq 85mA$			± 15	
Modulation Off Current		TX_DISABLE = high				0.1	mA
Modulation-Current Monitor Ratio		I_{MOD}/I_{MC_MON}		223	262	302	mA/mA
EXTINCTION RATIO CONTROLS							
Monitor-Diode Input Current Range	I_{MD}	Average current into the MD pin		18		1500	μA
MD Pin Voltage						1.4	V
MD-Current Monitor Ratio		I_{MD}/I_{PC_MON}		0.85	1.0	1.15	mA/mA
APC Loop Time Constant		$C_{APC_FILT} = 0.01\mu F$, $\Delta I_{MD}/\Delta I_{BIAS} = 1/70$			3.3		μs
APC Setting Stability					± 100	± 480	ppm/ $^\circ C$
APC Setting Accuracy		$T_A = +25^\circ C$				± 15	%
I_{MOD} Compensation Setting Range by Bias	K	$K = \Delta I_{MOD}/\Delta I_{BIAS}$		0		1.5	mA/mA
I_{MOD} Compensation Setting Range by Temperature	TC	$TC = \Delta I_{MOD}/\Delta T$ (Note 6)		0		1.0	mA/ $^\circ C$
Threshold Setting Range for Temperature Compensation	T_{TH}	(Note 6)		10		60	$^\circ C$
LASER SAFETY AND CONTROL							
Bias and Modulation Turn-Off Delay		$C_{APC_FILT} = 0.01\mu F$, $\Delta I_{MD}/\Delta I_{BIAS} = 1/80$ (Note 6)				5	μs
Bias and Modulation Turn-On Delay		$C_{APC_FILT} = 0.01\mu F$, $\Delta I_{MD}/\Delta I_{BIAS} = 1/80$ (Note 6)				600	μs
Threshold Voltage at Monitor Pins	V_{REF}	Figure 5		1.14	1.3	1.39	V
INTERFACE SIGNALS							
TX_DISABLE Input High	V_{HI}			2.0			V
TX_DISABLE Input Low	V_{LO}	$R_{PULL} = 7.5k\Omega$				0.8	V
TX_DISABLE Input Current		$V_{HI} = V_{CC}$				15	μA
		$V_{LO} = GND$				-450 -800	
TX_FAULT Output Low		Sinking 1mA, open collector				0.4	V
Shutdown Output High		Sourcing 100 μA		$V_{CC} - 0.4$			V
Shutdown Output Low		Sinking 100 μA				0.4	V

Note 1: AC characterization is performed using the circuit in Figure 2 using a PRBS 2²³ - 1 or equivalent test pattern.

Note 2: Specifications at $-40^\circ C$ are guaranteed by design and characterization.

Note 3: Excluding I_{BIAS} and I_{MOD} . Input data is AC-coupled. TX_FAULT open, SHUTDOWN open.

Note 4: Power-supply noise rejection (PSNR) = $20\log_{10}(V_{noise} \text{ (on } V_{CC})/\Delta V_{OUT})$. V_{OUT} is the voltage across the 15 Ω load when IN+ is high.

Note 5: The minimum required voltage at the OUT+ and OUT- pins is $+0.75V$.

Note 6: Guaranteed by design and characterization.

Note 7: Tested with 00001111 pattern at 2.7Gbps.

Note 8: DJ includes pulse-width distortion (PWD).

多速率激光驱动器， 带有消光比控制

典型工作特性

($V_{CC} = +3.3V$, $C_{APC} = 0.01\mu F$, $I_{BIAS} = 20mA$, $I_{MOD} = 30mA$, $T_A = +25^\circ C$, unless otherwise noted.)

OPTICAL EYE DIAGRAM
(2.7Gbps, 2⁷ - 1PRBS, 2.3GHz FILTER)

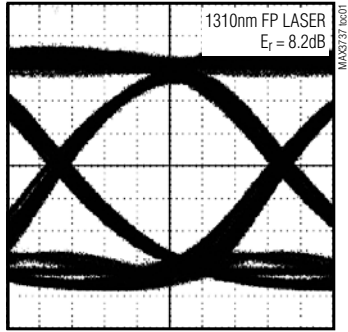

54ps/div

OPTICAL EYE DIAGRAM
(1.25Gbps, 2⁷ - 1PRBS, 940MHz FILTER)

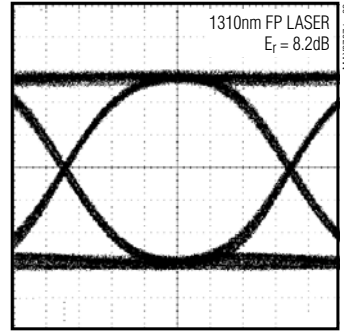

116ps/div

OPTICAL EYE DIAGRAM
(155Mbps, 2⁷ - 1PRBS, 117MHz FILTER, $C_{APC} = 0.1\mu F$)

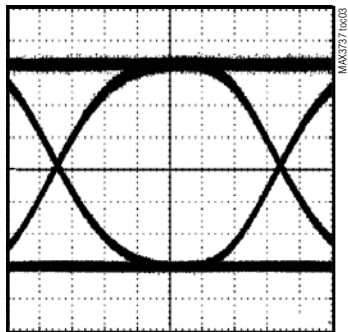

920ps/div

ELECTRICAL EYE DIAGRAM
($I_{MOD} = 30mA$, 2.7Gbps, 2⁷ - 1PRBS)

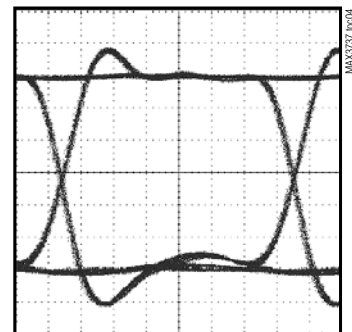

75mV/div

52ps/div

SUPPLY CURRENT (I_{CC}) vs. TEMPERATURE
(EXCLUDES BIAS AND MODULATION CURRENTS)

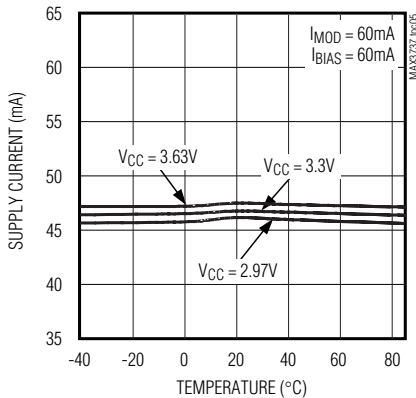

BIAS-CURRENT MONITOR GAIN vs. TEMPERATURE

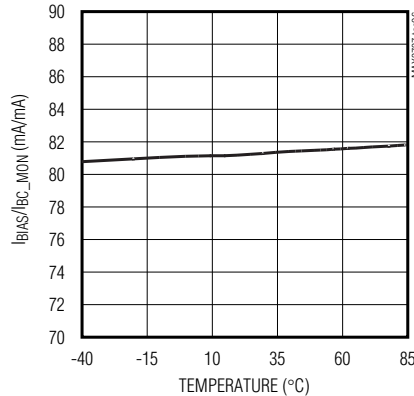
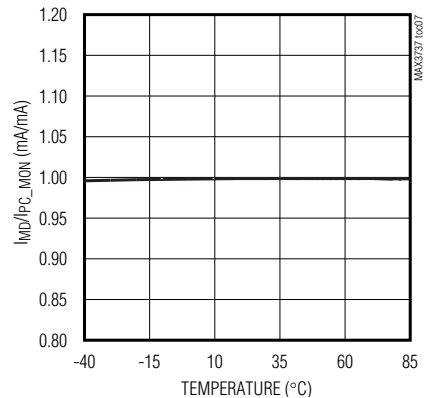

PHOTO-CURRENT MONITOR GAIN vs. TEMPERATURE



多速率激光驱动器， 带有消光比控制

典型工作特性 (续)

($V_{CC} = +3.3V$, $C_{APC} = 0.01\mu F$, $I_{BIAS} = 20mA$, $I_{MOD} = 30mA$, $T_A = +25^\circ C$, unless otherwise noted.)

MAX3737

MODULATION-CURRENT MONITOR GAIN vs. TEMPERATURE

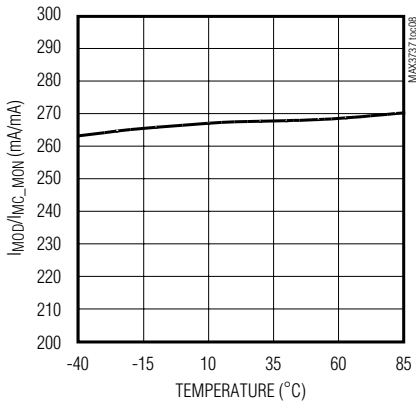

MODULATION CURRENT vs. R_MODSET

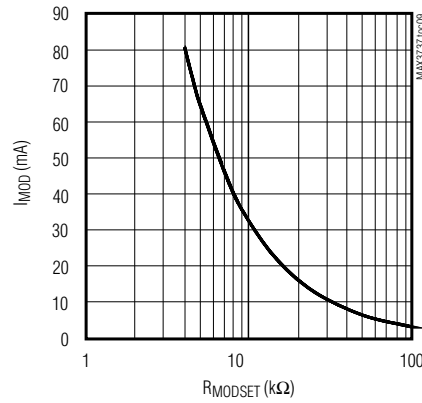

PHOTODIODE CURRENT vs. R_PCSET

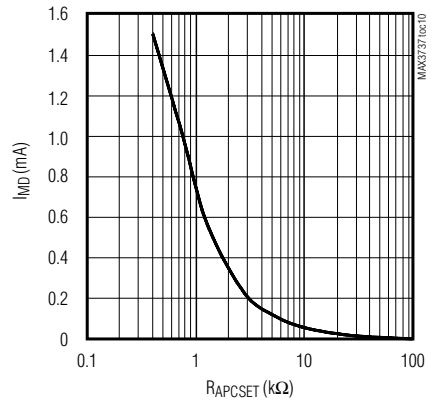

DETERMINISTIC JITTER vs. MODULATION CURRENT

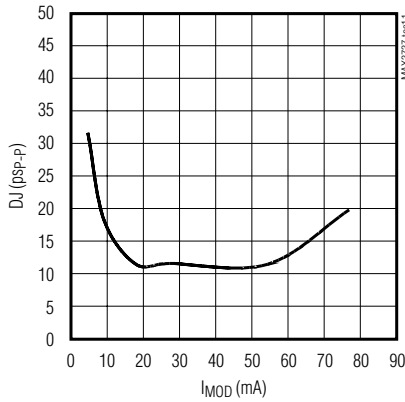

RANDOM JITTER vs. MODULATION CURRENT

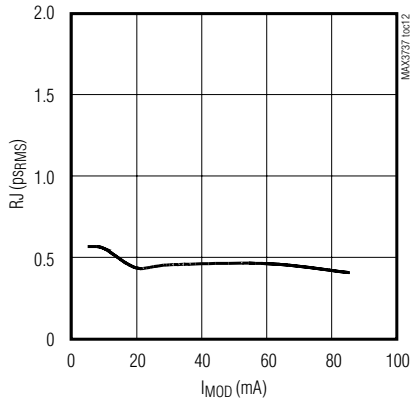

COMPENSATION (K) vs. R_MODBCOMP

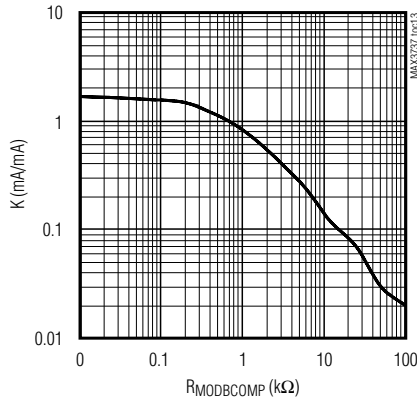

TEMPERATURE COMPENSATION vs. R_TH_TEMP (R_MODTCOMP = 500Ω)

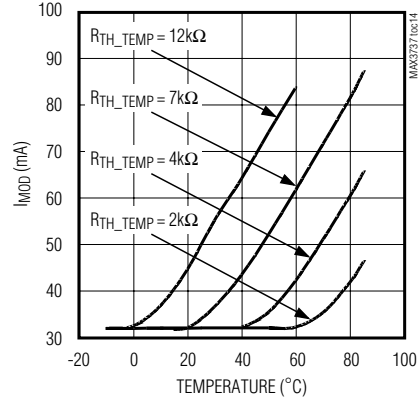

多速率激光驱动器， 带有消光比控制

典型工作特性 (续)

(VCC = +3.3V, CAPC = 0.01μF, IBIAS = 20mA, IMOD = 30mA, TA = +25°C, unless otherwise noted.)

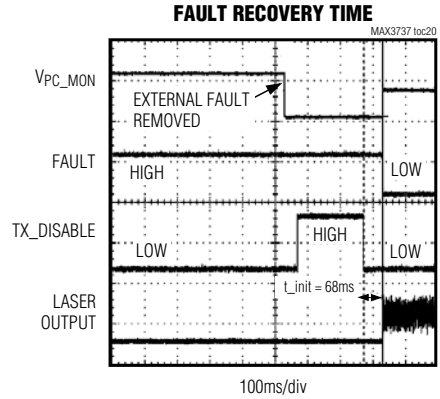
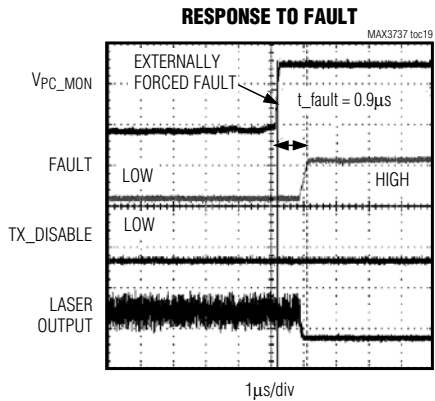
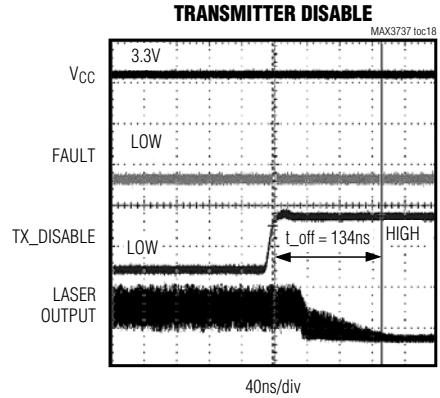
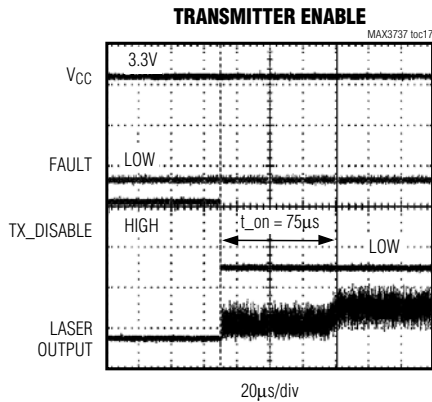
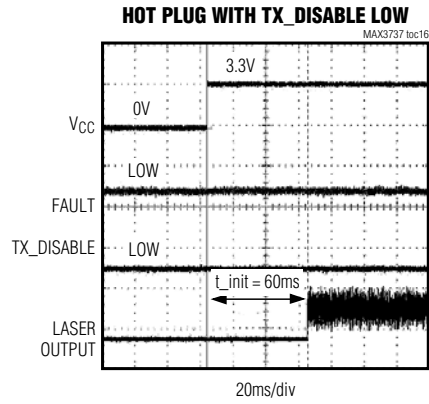
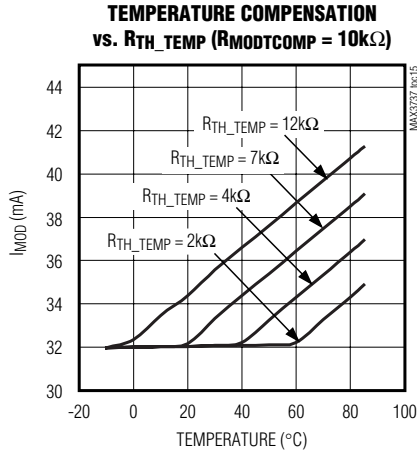

多速率激光驱动器， 带有消光比控制

引脚描述

MAX3737

引脚	名称	功能
1, 10, 15, 16	GND	电源地
2	TX_DISABLE	发送器禁止输入，TTL电平。在TX_DISABLE为高电平或浮空时，激光器输出被禁止。该引脚为低电平时，允许激光器输出。
3, 6, 11, 18, 23	VCC	+3.3V电源电压
4	IN+	同相数据输入
5	IN-	反相数据输入
7	PC_MON	光电流监测输出。该引脚输出电流经过一个外部电阻，将产生正比于监测二极管电流的对地参考输出电压。
8	BC_MON	偏置电流监视输出。该引脚输出电流经过一个外部电阻，将产生正比于偏置电流的对地参考输出电压。
9	MC_MON	调制电流监视输出。该引脚输出电流经过一个外部电阻，将产生正比于调制电流幅度的对地参考输出电压。
12	TX_FAULT	集电极开路输出的发送故障指示(表1)
13	SHUTDOWN	关断驱动器输出。电压输出控制外部晶体管，以选择关断某些电路。
14	VBS	偏置电压检测。在使用精密偏置检测电阻时，偏置输出的隔离抽头(3kΩ ±15%)减少了元件数量。
17	BIAS	激光器偏置电流输出。
19, 20	OUT-	调制电流反相输出。(将引脚19和20连接在一起)。输入数据为低电平时，I _{MOD} 流入此引脚。
21, 22	OUT+	调制电流同相输出。(将引脚21和22连接在一起)。输入数据为高电平时，I _{MOD} 流入此引脚。
24	MD	监测光电二极管输入。将此引脚连接到监测光电二极管的阳极。要求对地外接一只电容，以滤除高速交流监测光电流。
25	VMD	监测光电二极管电压检测。在使用精密偏置检测电阻时，MD输入的隔离抽头(3kΩ ±15%)减少了元件数量。
26	APCFILT1	在引脚26 (APCFILT1)和引脚27 (APCFILT2)之间连接一只电容，用于设置C _{APC} 反馈回路的主极点。
27	APCFILT2	(参见引脚26。)
28	APCSET	在此引脚和地之间连接一个电阻，用于设置所需的平均光功率。
29	MODSET	在此引脚和地之间连接一个电阻，用于设置所需的恒定调制电流部分。
30	MODBCOMP	基于偏置的调制电流补偿。将偏置电流耦合至调制电流。I _{BIAS} 的镜像电流流过一个外部电阻。无须耦合时，该引脚浮空。
31	TH_TEMP	用于温度补偿的门限。该引脚端的电阻设定温度门限，超出该温度将补偿调制电流。
32	MODTCOMP	调制电流温度补偿。该引脚端的电阻设置在超出温度门限时的调制电流温度补偿系数。无须温度补偿时，该引脚浮空。
EP	Exposed Pad	地。将裸露焊盘焊接到电路板地，以达到特定的散热和电气特性。

多速率激光驱动器， 带有消光比控制



图1. 所需的输入信号和输出极性



图2. 特征参数的测试电路

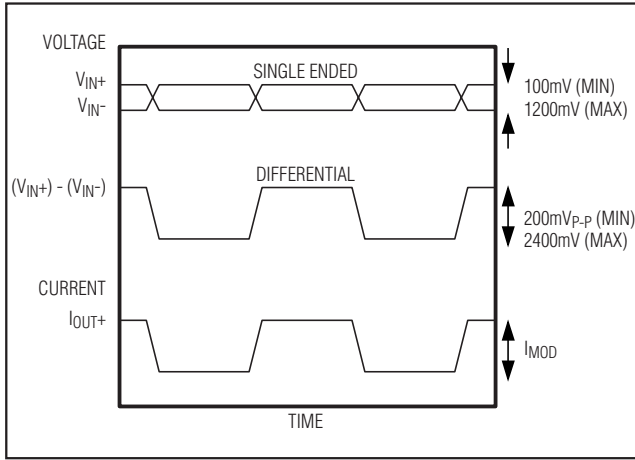

图3. 电源滤波器

详细说明

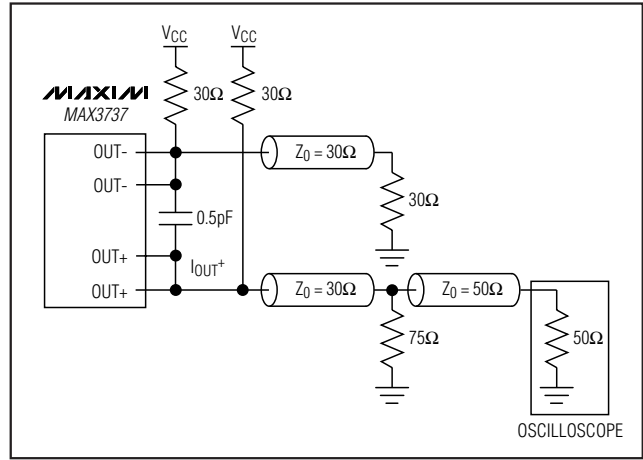
MAX3737激光驱动器包括三个主要单元：高速调制驱动器、带ERC的偏置电流单元及安全电路。该电路设计优化用于高速、低压(+3.3V)工作方式(图4)。

高速调制驱动器

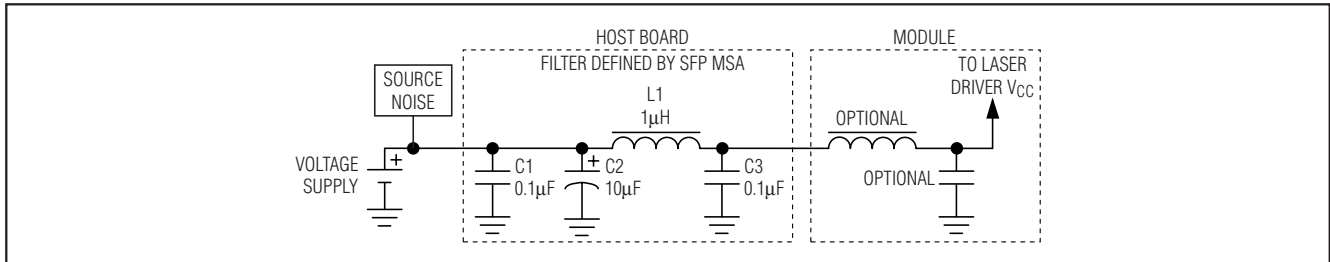
输出级由一对高速差分信号和一个可编程的调制电流源组成。MAX3737被优化用于驱动15Ω负载。在调制电流达到60mA时，OUT+端所需的最小瞬变电压为0.7V；而电流在60mA至85mA之间时要求0.75V。超过60mA时可用交流耦合，或保证激光器上具有足够的电压，以达到驱动器输出电压的要求。

与激光器二极管连接，需要一个阻尼电阻(R_D)。阻尼电阻和激光器二极管等效串联电阻的总和应等于15Ω。为了进一步衰减由激光器二极管寄生电感产生的过冲，可能还需要并联一个RC网络。更多信息请参考Maxim应用笔记 HFAN 02.0: *Interfacing Maxim's Laser Drivers to Laser Diodes*。

在2.7Gbps数据速率下，激光器二极管阴极上的任何容性负载会降低光输出特性。因为BIAS输出是直接连接到激光器阴极，可以通过一个电感来隔离BIAS引脚与激光器阴极，以尽可能减小该引脚上的寄生电容。

消光比控制

消光比(r_e)为激光器导通状态的功率除以关断状态的功率。若峰峰值和平均功率保持不变，则消光比保持恒定：

$$r_e = (2P_{AVG} + P_{P-P}) / (2P_{AVG} - P_{P-P})$$

通过APC调节平均功率，保持从激光器耦合到光电二极管的电流恒定。激光器斜率效率(η)降低时，通过补偿调制电流能够在整个有效使用期限内和温度范围内保持峰值功率恒定：

$$P_{AVG} = \frac{I_{MD}}{PMON}$$

$$P_{P-P} = \eta \times I_{MOD}$$

多速率激光驱动器， 带有消光比控制

MAX3737



图4. 功能图

基于偏置的调制补偿根据用户选择的比率 (K) 增加调制电流，以便在偏置电流随着温度而增加时保持峰值激光功率不变。详细资料请参考Maxim应用笔记HFAN-02.2.1：

$$K = \frac{\Delta I_{MOD}}{\Delta I_{BIAS}}$$

这提供了所要增加电流的一次逼近，以保持峰值功率恒定。斜率效率随着温度增加将明显降低。当温度超出用户定义的门槛 (T_{TH}) 后，MAX3737 还可提供额外的温度补偿。

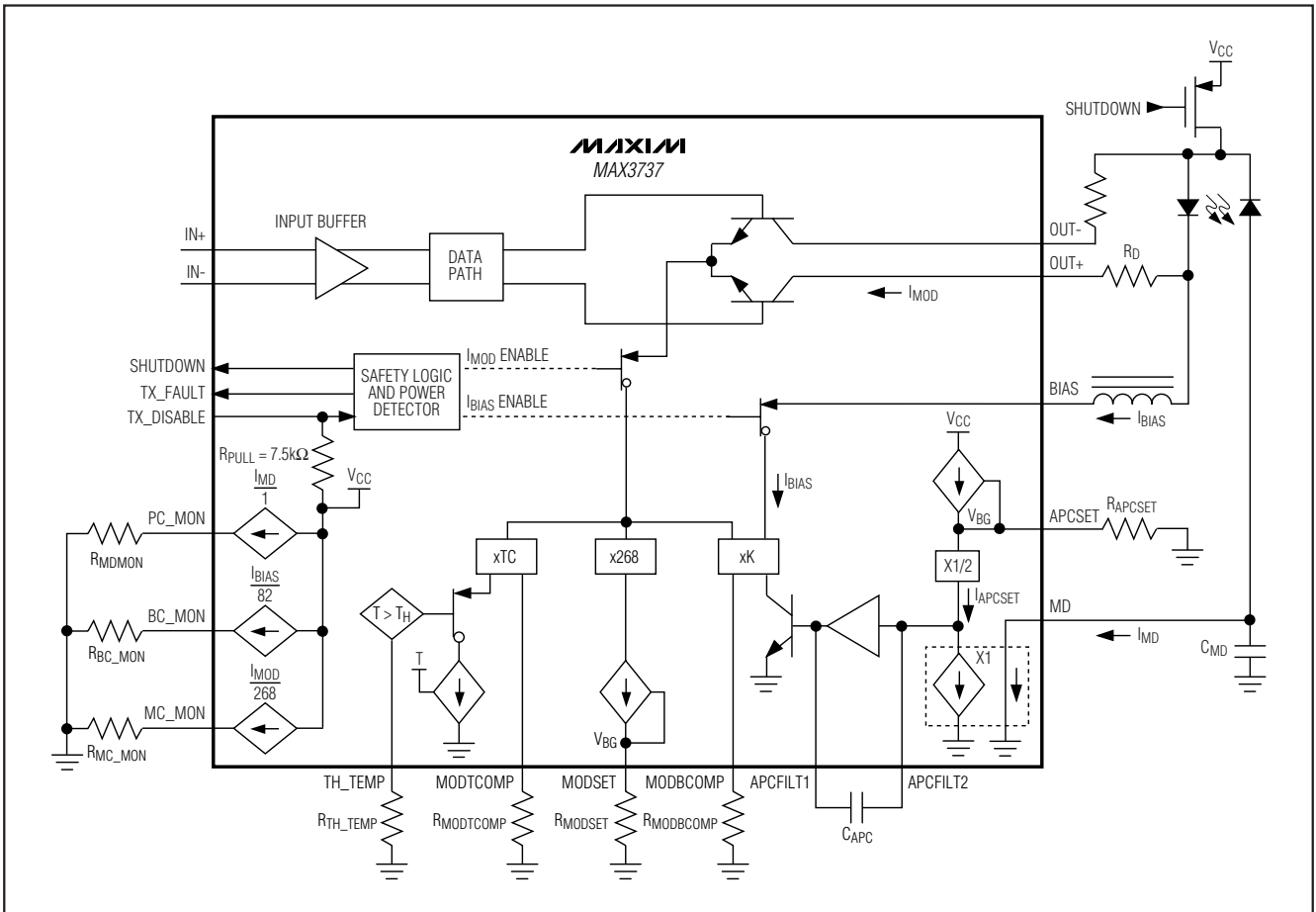
安全电路

安全电路包括一个禁止输入 (TX_DISABLE)、锁存故障输出 (TX_FAULT) 和故障检测器 (图5)。该电路监测激光驱动器的工作情况，并在检测 (表1) 到故障时强制关断。根据 SFP MSA 的要求，TX_FAULT 引脚用一个 4.7kΩ 至 10kΩ 电阻连接到 V_{CC}，将其上拉到高电位。单点故障可能是短路至 V_{CC} 或 GND。参阅表2，以便查看不同单点故障下的电路响应。发送故障条件会一直被锁存，直到触发 TX_DISABLE 或 V_{CC} 复位为止。激光驱动器通过可选的关断控制电路，可以提供冗余的激光器二极管关断方式，如典型工作电路所示。关断晶体管避免了由于激光器的单点故障而发生不安全的状况。

多速率激光驱动器， 带有消光比控制

表1. 典型故障条件

1	If any of the I/O pins is shorted to GND or V _{CC} (single-point failure; see Table 2), and the bias current or the photocurrent exceed the programmed threshold.
2	End-of-life (EOL) condition of the laser diode. The bias current and/or the photocurrent exceed the programmed threshold.
3	Laser cathode is grounded and photocurrent exceeds the programming threshold.
4	No feedback for the APC loop (broken interconnection, defective monitor photodiode), and the bias current exceeds the programmed threshold.

表2. 不同单点故障的电路响应

PIN	CIRCUIT RESPONSE TO OVERVOLTAGE OR SHORT TO V _{CC}	CIRCUIT RESPONSE TO UNDERVOLTAGE OR SHORT TO GROUND
TX_FAULT	Does not affect laser power.	Does not effect laser power.
TX_DISABLE	Modulation and bias currents are disabled.	Normal condition for circuit operation.
IN+	The optical average power increases and a fault occurs if V _{PC_MON} exceeds the threshold. The APC loop responds by decreasing the bias current.	The optical average power decreases and the APC loop responds by increasing the bias current. A fault state occurs if V _{BC_MON} exceeds the threshold voltage.
IN-	The optical average power decreases and the APC loop responds by increasing the bias current. A fault state occurs if V _{BC_MON} exceeds the threshold voltage.	The optical average power increases and a fault occurs if V _{PC_MON} exceeds the threshold. The APC loop responds by decreasing the bias current.
MD	This disables bias current. A fault state occurs.	The APC circuit responds by increasing bias current until a fault is detected, then a fault* state occurs.
SHUTDOWN	Does not affect laser power. If the shutdown circuitry is used, laser current is disabled.	Does not affect laser power.
BIAS	In this condition, laser forward voltage is 0V and no light is emitted.	Fault state* occurs. If the shutdown circuitry is used, laser current is disabled.
OUT+	The APC circuit responds by increasing the bias current until a fault is detected, then a fault state* occurs.	Fault state* occurs. If the shutdown circuitry is used, laser current is disabled.
OUT-	Does not affect laser power.	Does not affect laser power.
PC_MON	Fault state* occurs.	Does not affect laser power.
BC_MON	Fault state* occurs.	Does not affect laser power.
MC_MON	Fault state* occurs.	Does not affect laser power.
APCFILT1	I _{BIAS} increases until V _{BC_MON} exceeds the threshold voltage.	I _{BIAS} increases until V _{BC_MON} exceeds the threshold voltage.
APCFILT2	I _{BIAS} increases until V _{BC_MON} exceeds the threshold voltage.	I _{BIAS} increases until V _{BC_MON} exceeds the threshold voltage.
MODSET	Does not affect laser power.	Fault state* occurs.
APCSET	Does not affect laser power.	Fault state* occurs.

*A fault state asserts the TX_FAULT pin, disables the modulation and bias currents, and asserts the SHUTDOWN pin.

安全电路电流监视器

MAX3737具有监视 (MC_MON、BC_MON、PC_MON) 调制电流 (I_{MOD})、偏置电流 (I_{BIAS})和光电流 (I_{MD})的特

性。监视功能通过镜像部分电流，并使其流过外部接地电阻而产生电压的方法来实现。MC_MON、PC_MON或BC_MON端电压大于V_{REF}电压时产生故障状态。例如，

多速率激光驱动器， 带有消光比控制

在每个监视器输出端连接到一个 100Ω 电阻接地，可得出下列关系：

$$V_{MC_MON} = (I_{MOD} / 268) \times 100\Omega$$

$$V_{BC_MON} = (I_{BIAS} / 82) \times 100\Omega$$

$$V_{PC_MON} = I_{MD} \times 100\Omega$$

可以用外部检测电阻高精度测量偏置电流和光电二极管电流。片内隔离电阻可以减少实现该功能所需要的元件数量。

设计步骤

在设计激光驱动器时，光输出通常采用平均光功率和消光比的形式来表示。表 3 给出的关系式对平均光功率和调制电流之间的转换很有帮助。这些关系式在符号密度和光波形占空比为 50% 时有效。

要得到预期的激光器平均光功率 (P_{AVG}) 和光学消光比 (r_e)，所需的偏置电流和调制电流可用表 3 中的方程式来计算。这些电流的合理设置要求了解激光器特性，以监测传输效率 (ρ_{MON}) 和斜率效率 (η)。

设定监测二极管电流 设置点

MAX3737 在所有时间内都工作在 APC 模式。偏置电流将自动设置，所以平均激光器功率由 APCSET 电阻决定：

$$P_{AVG} = \frac{I_{MD}}{\rho_{MON}}$$

APCSET 引脚控制监测二极管电流的设置点。内置电流调节器建立 APCSET 电流，方式和 MODSET 引脚相同。参考典型工作特性中的 I_{MD} 与 R_{APCSET} 关系图，选择 +25°C 下所需电流对应的 R_{APCSET} 值。

$$I_{MD} = \frac{1}{2} \times \frac{V_{REF}}{R_{APCSET}}$$

激光驱动器自动调整偏置，以保持恒定的平均功率。对于直流耦合的激光器二极管：

$$I_{AVG} = I_{BIAS} + \frac{I_{MOD}}{2}$$

对带补偿的调制电流进行设定

由激光器的斜率效率决定调制电流：

$$I_{MOD} = 2 \times \frac{P_{AVG}}{\eta} \times \frac{r_e - 1}{r_e + 1}$$

MAX3737 的调制电流由静态调制电流 (I_{MODS})、与 I_{BIAS} 成比例的电流和与温度成比例的电流组成。由 MODSET 设置 I_{MOD} 的电流是通过内部建立的，该电流调节器将保持外部编程电阻上的 V_{REF} 参考电压不变。参考典型工作特性中的 I_{MOD} 与 R_{MODSET} 关系图，选择 +25°C 下所需电流对应的 R_{MODSET} 值。

表 3. 光功率关系式

PARAMETER	SYMBOL	RELATION
Average power	P_{AVG}	$P_{AVG} = (P_0 + P_1) / 2$
Extinction ratio	r_e	$r_e = P_1 / P_0$
Optical power of a 1	P_1	$P_1 = 2P_{AVG} r_e / (r_e + 1)$
Optical power of a zero	P_0	$P_0 = 2P_{AVG} / (r_e + 1)$
Optical amplitude	P_{P-P}	$P_{P-P} = P_1 - P_0$
Laser slope efficiency	η	$\eta = P_{P-P} / I_{MOD}$
Modulation current	I_{MOD}	$I_{MOD} = P_{P-P} / \eta$
Threshold current	I_{TH}	P_0 at $I \geq I_{TH}$
Bias current (AC-coupled)	I_{BIAS}	$I_{BIAS} \geq I_{TH} + I_{MOD} / 2$
Laser to monitor transfer	ρ_{MON}	I_{MD} / P_{AVG}

Note: Assuming a 50% average input duty cycle and mark density.

多速率激光驱动器， 带有消光比控制

$$I_{MOD} = I_{MODS} + K \times I_{BIAS} + I_{MODT}$$

$$I_{MODS} = 268 \times \frac{V_{REF}}{R_{MODSET}}$$

$$I_{MODT} = TC \times (T - T_{TH}) \quad | \quad T > T_{TH}$$

$$I_{MODT} = 0 \quad | \quad T \leq T_{TH}$$

MODBCOMP引脚上的外部电阻用来设置与 I_{BIAS} 成比例的电流。MODBCOMP引脚开路将断开 I_{BIAS} 与 I_{MOD} 之间的耦合关系：

$$K = \frac{1700}{1000 + R_{MODBCOMP}} \pm 10\%$$

若 I_{MOD} 必须从 I_{MOD1} 增加到 I_{MOD2} ，以便使消光比在高温下保持不变，所需的补偿因数为：

$$K = \frac{I_{MOD2} - I_{MOD1}}{I_{BIAS2} - I_{BIAS1}}$$

附加温度补偿的门限通过 T_{H_TEMP} 引脚的电阻来设定：

$$T_{TH} = -70^{\circ}\text{C} + \frac{1.45\text{M}\Omega}{9.2\text{k}\Omega + R_{TH_TEMP}}^{\circ}\text{C} \pm 10\%$$

超过 T_{TH} 的温度补偿系数由 $R_{MODTCOMP}$ 来设置。MODT-COMP引脚开路将禁止附加的温度补偿：

$$TC = \frac{1}{0.5 + R_{MODTCOMP}(\text{k}\Omega)} \frac{\text{mA}}{^{\circ}\text{C}} \pm 10\%$$

**电流条件 ($I_{MOD} \leq 60\text{mA}$),
直流耦合**

OUT+和OUT-上的最小电压为0.7V。

对于：

V_{DIODE} — 二极管偏置点电压 (1.2V典型值)

R_L — 二极管偏置点电阻 (5 Ω 典型值)

R_D — 串联匹配电阻 (20 Ω 典型值)

为了满足电流条件：

$$V_{OUT+} = V_{CC} - V_{DIODE} - I_{MOD} \times (R_D + R_L) - I_{BIAS} \times R_L \geq 0.7\text{V}$$

**电流条件 ($I_{MOD} > 60\text{mA}$),
交流耦合**

对于要求调制电流大于60mA的应用来说，若激光器采用直流耦合，则激光驱动器正常工作的电压空间可能不够。为避免出现该问题，MAX3737的调制输出可采用交流耦合至激光二极管的阴极。所必需的外部上拉电感将调制输出直流偏置至 V_{CC} 。这样的配置使激光器正向电压与输出电路隔离，并允许OUT+端的输出在电源电压(V_{CC})上下摆动。在交流耦合时，MAX3737调制电流可编程到85mA。查询有关交流耦合激光驱动器到激光器二极管的更多信息，参考Maxim应用笔记HFAN 02.0: *Interfacing Maxim's Laser Drivers to Laser Diodes*。

为满足电流条件：

$$V_{OUT+} = V_{CC} - \frac{I_{MOD}}{2} \times (R_D + R_L) \geq 0.75\text{V}$$

确定 C_{APC}

必须合理选择APC回路滤波电容 C_{APC} ，以折衷考虑快速开启和低频条件下的码形干扰。低频截止对应的电容为：

$$C_{APC}(\mu\text{F}) \approx \frac{68}{f_{3\text{DB}}(\text{kHz})} \times (\eta \times \rho_{\text{MON}})^{1.1}$$

高频噪声可用MD引脚与地之间的外部电容 C_{MD} 来滤除：

$$C_{MD} \approx \frac{C_{APC}}{4}$$

设计MAX3737，以便开启时间小于1ms，以适合大多数激光器增益值($\eta \times \rho_{\text{MON}}$)。选择更小的 C_{APC} 值，将减少开启时间。对于某些增益值，在低数据速率下需要仔细考虑开启时间和低频截止频率。

接口模型

图6和图7给出了简化的MAX3737激光驱动器的输入和输出电路。若采用裸片，则采用绑定线寄生参数代替封装寄生参数。

多速率激光驱动器， 带有消光比控制

MAX3737



图5. 简化的安全电路



图6. 简化的输入结构

布局考虑因素

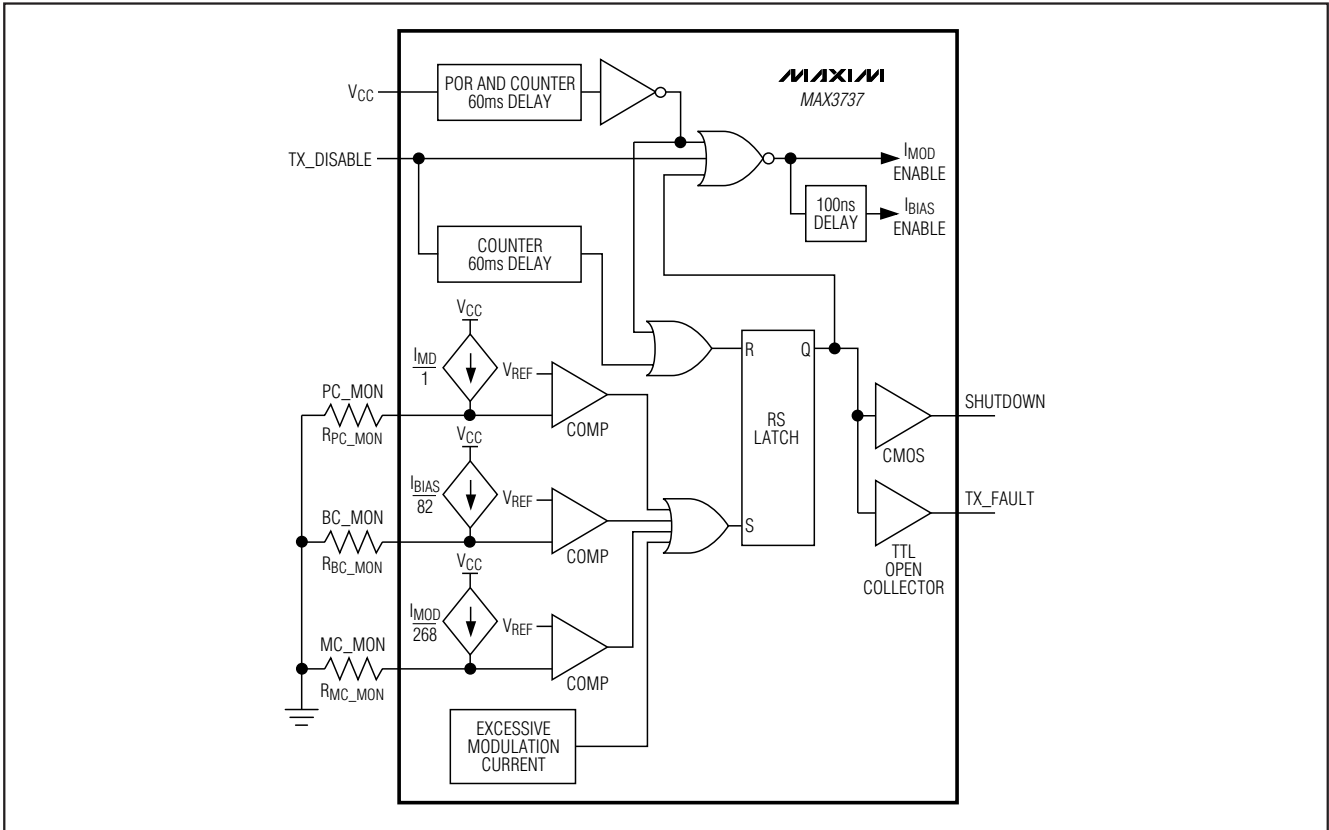
为尽可能降低损耗和串扰，保持MAX3737输出和激光器二极管的连接尽可能地短。采用很好的高频布局技巧和带有不间断地线层的多层电路板，以最小化EMI和串扰。应该采用低损耗绝缘电路板。同时，数据输入和模块输出应该采用阻抗受控的传输线。

激光器安全及IEC825

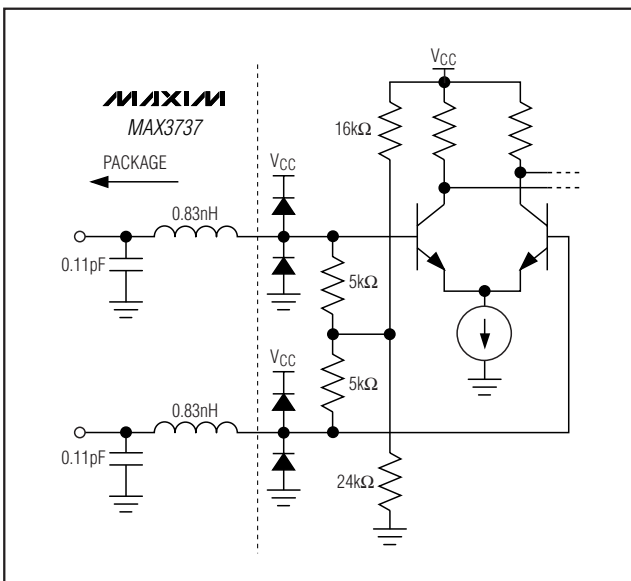
单独使用MAX3737激光驱动器不保证发送器设计符合IEC 825。必须考虑到整个发送器电路和元件的选择。每个用户必须确定其系统应用中要求的容错级别，要确认Maxim产品不是设计或授权用于外科移植手术、维持生命的应用，及其它任何因Maxim产品的故障会可能发生导致人身伤亡的应用。

多速率激光驱动器， 带有消光比控制

裸露焊盘封装

32引脚QFN封装上的裸露焊盘为IC散热提供了极低的热阻抗通路。焊盘也是MAX3737的电路地，且应焊接到电路板地，以便达到合适的温度特性和电气特性。参考Maxim应用笔记HFAN-08.1: *Thermal Considerations for QFN and Other Exposed Pad Packages*，其它信息请浏览 www.maxim-ic.com.cn。



图7. 简化的输出结构

引脚配置 (续)

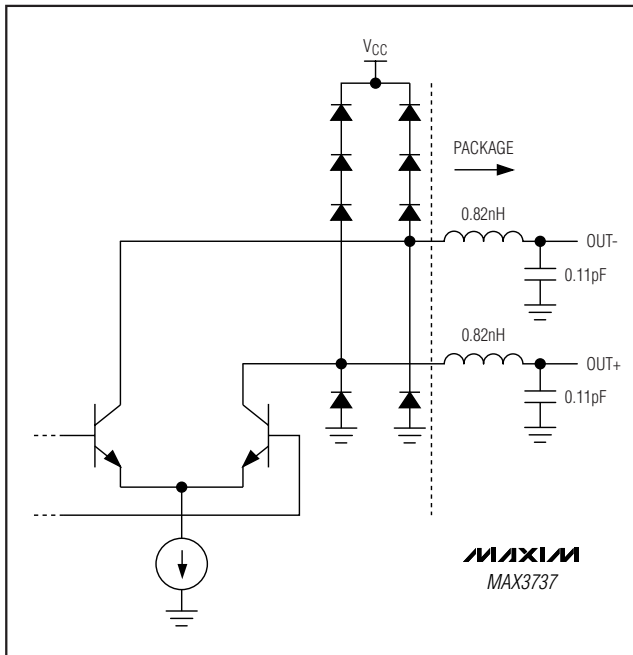
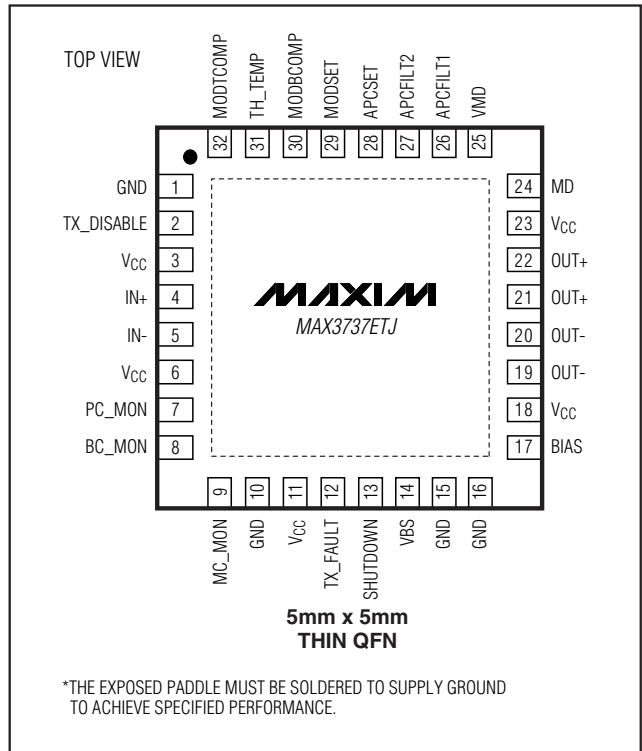

芯片信息

TRANSISTOR COUNT: 2727

PROCESS: SiGe/Bipolar

多速率激光驱动器， 带有消光比控制

典型工作电路

MAX3737

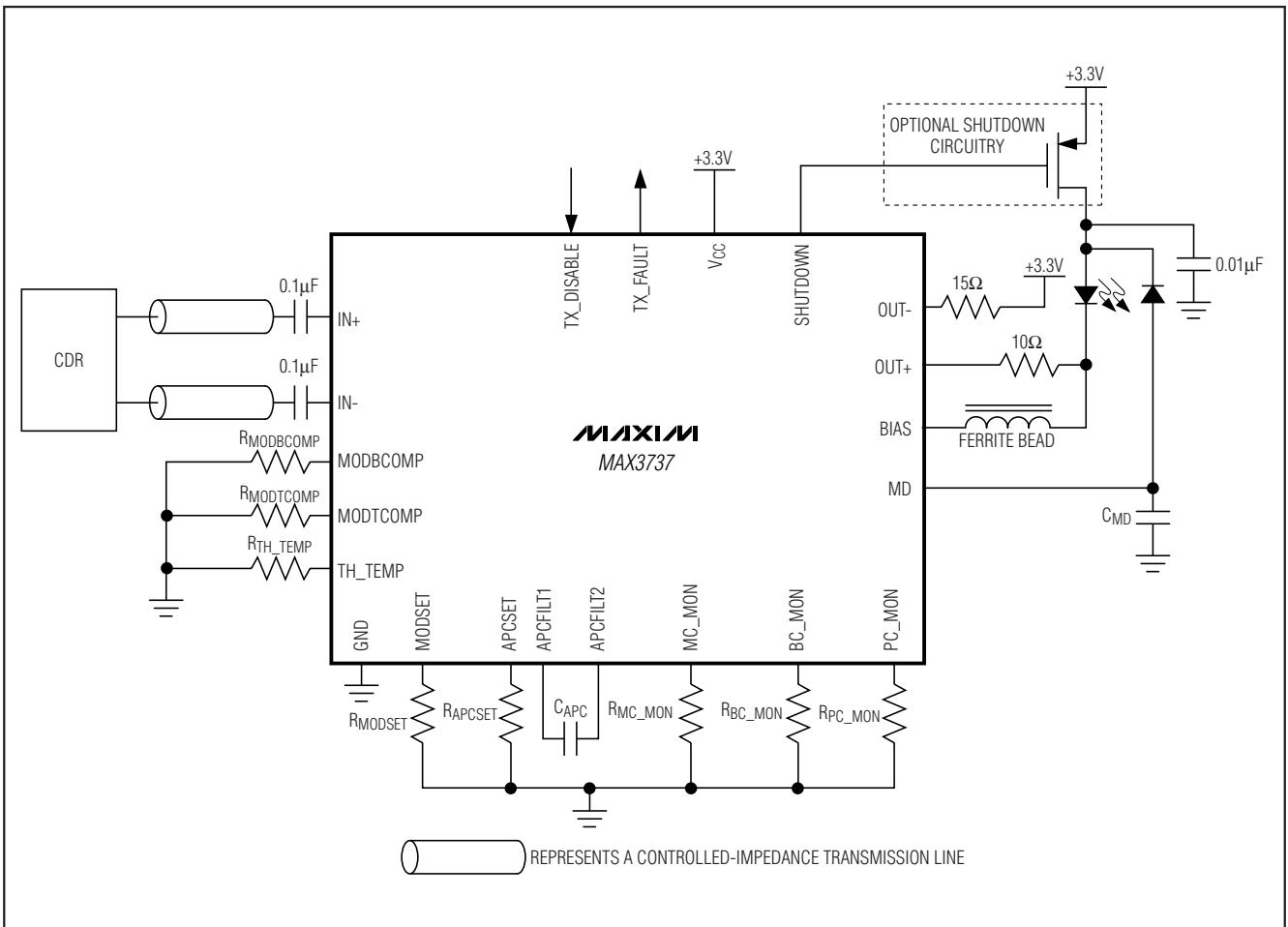

多速率激光驱动器， 带有消光比控制

封装信息

(本数据资料提供的封装图可能不是最近的规格，如需最近的封装外型信息，请查询 www.maxim-ic.com.cn/packages。)

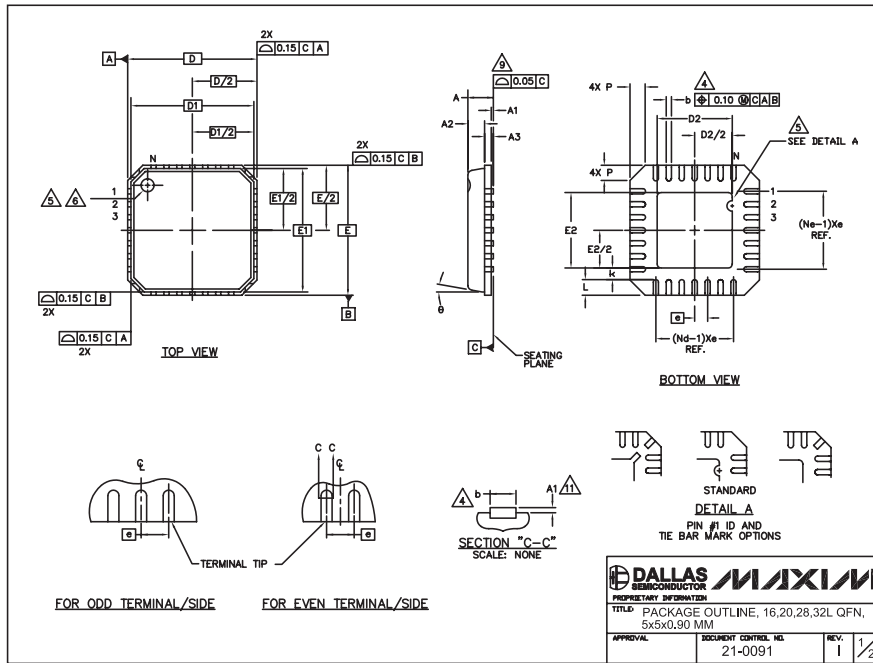

32L QFN EP5

COMMON DIMENSIONS												
PKG	16L 5x5			20L 5x5			28L 5x5			32L 5x5		
SYMBOL	MIN.	NOM.	MAX.	MIN.	NOM.	MAX.	MIN.	NOM.	MAX.	MIN.	NOM.	MAX.
A	0.80	0.90	1.00	0.80	0.90	1.00	0.80	0.90	1.00	0.80	0.90	1.00
A1	0.00	0.01	0.05	0.00	0.01	0.05	0.00	0.01	0.05	0.00	0.01	0.05
A2	0.00	0.65	1.00	0.00	0.65	1.00	0.00	0.65	1.00	0.00	0.65	1.00
A3	0.20 REF.			0.20 REF.			0.20 REF.			0.20 REF.		
b	0.28	0.33	0.40	0.23	0.28	0.35	0.18	0.23	0.30	0.18	0.23	0.30
D	4.90	5.00	5.10	4.90	5.00	5.10	4.90	5.00	5.10	4.90	5.00	5.10
D1	4.75 BSC			4.75 BSC			4.75 BSC			4.75 BSC		
E	4.90	5.00	5.10	4.90	5.00	5.10	4.90	5.00	5.10	4.90	5.00	5.10
E1	4.75 BSC			4.75 BSC			4.75 BSC			4.75 BSC		
e	0.80 BSC			0.65 BSC			0.50 BSC			0.50 BSC		
k	0.25	-	-	0.25	-	-	0.25	-	-	0.25	-	-
L	0.35	0.55	0.75	0.35	0.55	0.75	0.35	0.55	0.75	0.30	0.40	0.50
N	16			20			28			32		
ND	4			5			7			8		
NE	4			5			7			8		
P	0.00	0.42	0.60	0.00	0.42	0.60	0.00	0.42	0.60	0.00	0.42	0.60
θ	0°			12°			0°			12°		

EXPOSED PAD VARIATIONS						
PKG. CODES	DE			E2		
	MIN.	NOM.	MAX.	MIN.	NOM.	MAX.
G1655-3	2.95	3.10	3.25	2.95	3.10	3.25
G2855-1	2.55	2.70	2.85	2.55	2.70	2.85
G2855-2	2.95	3.10	3.25	2.95	3.10	3.25
G2855-1	2.55	2.70	2.85	2.55	2.70	2.85
G2855-2	2.95	3.10	3.25	2.95	3.10	3.25
G3255-1	2.95	3.10	3.25	2.95	3.10	3.25

NOTES:

- DIE THICKNESS ALLOWABLE IS 0.305mm MAXIMUM (.012 INCHES MAXIMUM)
- DIMENSIONING & TOLERANCES CONFORM TO ASME Y14.5M. - 1994.
- N IS THE NUMBER OF TERMINALS.
Nd IS THE NUMBER OF TERMINALS IN X-DIRECTION & Ne IS THE NUMBER OF TERMINALS IN Y-DIRECTION.
9. DIMENSION b APPLIES TO PLATED TERMINAL AND IS MEASURED BETWEEN 0.20 AND 0.25mm FROM TERMINAL TIP.
- THE PIN #1 IDENTIFIER MUST BE EXISTED ON THE TOP SURFACE OF THE PACKAGE BY USING INDENTATION MARK OR INK/LASER MARKED. DETAILS OF PIN #1 IDENTIFIER IS OPTIONAL, BUT MUST BE LOCATED WITHIN ZONE INDICATED.
- EXACT SHAPE AND SIZE OF THIS FEATURE IS OPTIONAL.
- ALL DIMENSIONS ARE IN MILLIMETERS.
- PACKAGE WARPAGE MAX 0.05mm.
9. APPLIED FOR EXPOSED PAD AND TERMINALS. EXCLUDE EMBEDDED PART OF EXPOSED PAD FROM MEASURING.
- MEETS JEDEC MO220; EXCEPT DIMENSION "b".
- APPLIED FOR EXPOSED PAD AND TERMINALS. EXCLUDE EMBEDDING PART OF EXPOSED PAD FROM MEASURING.
- THIS PACKAGE OUTLINE APPLIES TO ANVIL SINGULATION (STEPPED SIDES).

DALLAS SEMICONDUCTOR MAXIM
 PROPRIETARY INFORMATION
 TITLE: PACKAGE OUTLINE, 16,20,28,32L QFN, 5x5x0.90 MM
 APPROVAL: [] DOCUMENT CONTROL NO. 21-0091 REV. I 1/2

